

| | | | | |
|-----------------|---------|-----------|------------|---------|
| Revision Notes. | | | | |
| R1 - | | | | |
| APA: - | Drawn:- | Checked:- | Approved:- | Date: - |

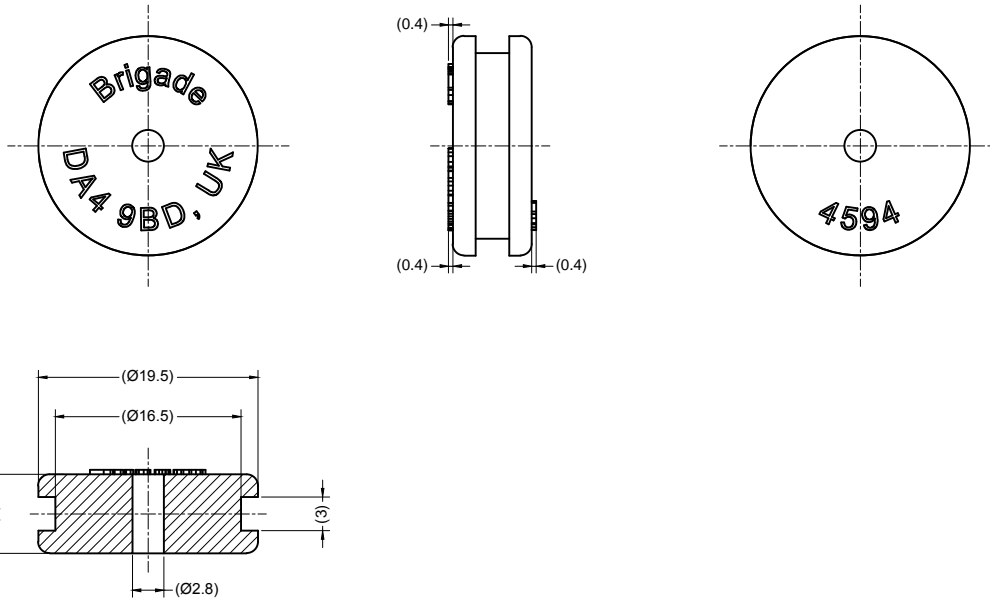

- NOTES:**
1. MATERIAL: SILICA, BLACK HARDNESS 50±3HA
 2. NO SURFACE COATING.
 3. REFER TO ASSEMBLY PLANT DRAWING SV0118 REV 0.0 FOR DETAILED DIMENSIONS.
 4. PART CANNOT BE DEFORMED AND WARPED

PROPRIETARY NOTICE
 THIS DESIGN AND TECHNICAL INFORMATION APPEARING ON THIS DRAWING IS THE PROPERTY OF BRIGADE ELECTRONICS, AND IS DISCLOSED IN CONFIDENCE. IT IS NOT TO BE COPIED, REPRODUCED, REVEALED TO OR EXPROPRIATED BY OTHERS, EITHER IN WHOLE OR IN PART WITHOUT THE EXPRESS WRITTEN CONSENT OF BRIGADE ELECTRONICS.



| | | | |
|------------------------------------|-----------------------|-----------------------------|-------------------------|
| Assembly Pt Approval G.WU | Approved by B.JOHN | Checked by R.BATES | Drawn by A.FEDERIGHI |
| Angle of Projection Third Angle | Units mm | Scale N/A | Released 28/05/14 |
| | Status RELEASED | Assembly Ref VBV-3XXC-RG | |
| | Part No 4594 | BE-002728-00-13 | |